

Today: Coda, xFS

- Distributed File Systems
- Case Study: Coda File System

- Brief overview of other file systems
 - xFS
 - Log structured file systems
 - HDFS
 - Object Storage Systems



Coda Overview

- DFS designed for mobile clients
 - Nice model for mobile clients who are often disconnected
 - Use file cache to make *disconnection* transparent
 - At home, on the road, away from network connection
- Coda supplements file cache with user preferences
 - E.g., always keep this file in the cache
 - Supplement with system learning user behavior
- How to keep cached copies on disjoint hosts consistent?
 - In mobile environment, “simultaneous” writes can be separated by hours/days/weeks



File Identifiers

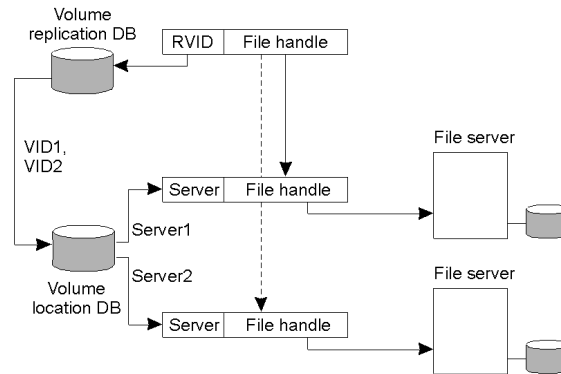

- Each file in Coda belongs to exactly one volume
 - Volume may be replicated across several servers
 - Multiple logical (replicated) volumes map to the same physical volume
 - 96 bit file identifier = 32 bit RVID + 64 bit file handle



Server Replication

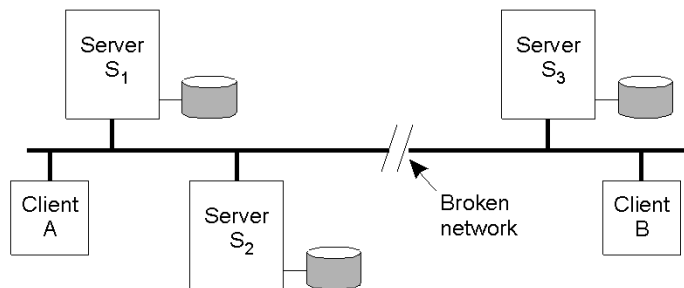

- Use replicated writes: read-once write-all
 - Writes are sent to all AVSG (all accessible replicas)
- How to handle network partitions?
 - Use optimistic strategy for replication
 - Detect conflicts using a Coda version vector
 - Example: $[2,2,1]$ and $[1,1,2]$ is a conflict \Rightarrow manual reconciliation



Disconnected Operation

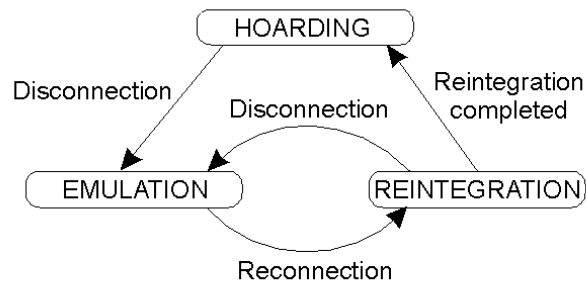

- The state-transition diagram of a Coda client with respect to a volume.
- Use hoarding to provide file access during disconnection
 - Prefetch all files that may be accessed and cache (hoard) locally
 - If AVSG=0, go to emulation mode and reintegrate upon reconnection



Transactional Semantics

- Network partition: part of network isolated from rest
 - Allow conflicting operations on replicas across file partitions
 - Reconcile upon reconnection
 - Transactional semantics => operations must be serializable
 - Ensure that operations were serializable after they have executed
 - Conflict => force manual reconciliation



Client Caching

- Cache consistency maintained using callbacks

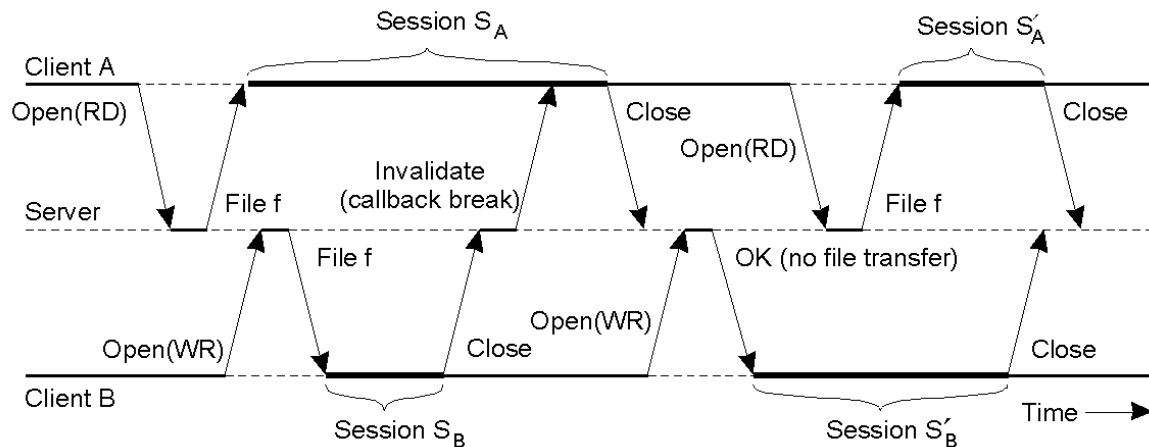

Overview of xFS.

- Key Idea: fully distributed file system [serverless file system]
 - Remove the bottleneck of a centralized system
- xFS: x in “xFS” => no server
- Designed for high-speed LAN environments

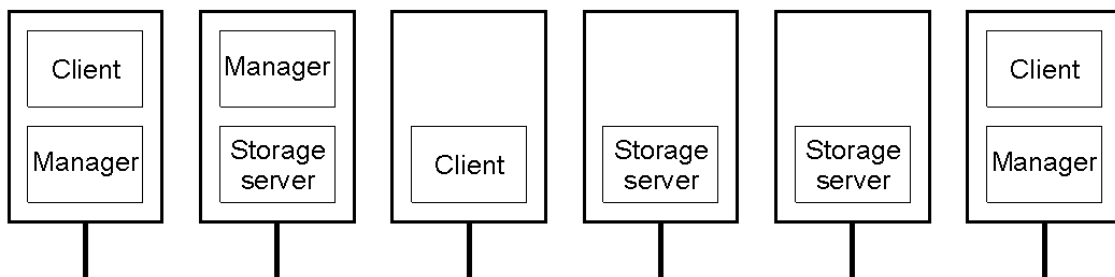

xFS Summary

- Distributes data storage across disks using software RAID and log-based network striping
 - RAID == Redundant Array of Independent Disks
- Dynamically distribute control processing across all servers on a per-file granularity
 - Utilizes serverless management scheme
- Eliminates central server caching using cooperative caching
 - Harvest portions of client memory as a large, global file cache.



RAID Overview

- Basic idea: files are "striped" across multiple disks
- Redundancy yields high data availability
 - Availability: service still provided to user, even if some components failed
- Disks will still fail
- Contents reconstructed from data redundantly stored in the array
 - Capacity penalty to store redundant info
 - Bandwidth penalty to update redundant info

Slides courtesy David Patterson



Array Reliability

- Reliability of N disks = Reliability of 1 Disk ÷ N
50,000 Hours ÷ 70 disks = 700 hours
Disk system MTTF: Drops from 6 years to 1 month!
- Arrays (without redundancy) too unreliable to be useful!

Hot spares support reconstruction in parallel with access: very high media availability can be achieved



Redundant Arrays of Inexpensive Disks RAID 1: Disk Mirroring/Shadowing

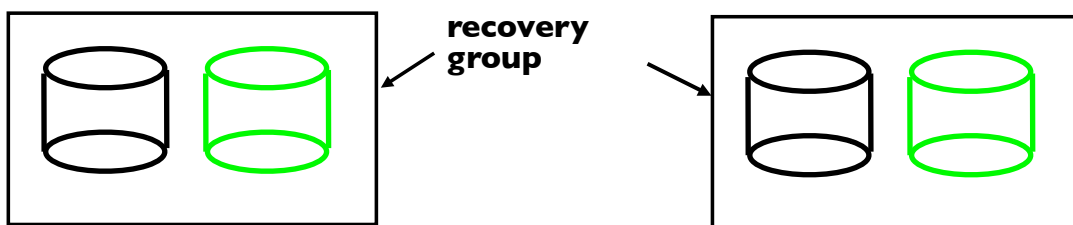

- Each disk is fully duplicated onto its “**mirror**”
 - Very high availability can be achieved
- Bandwidth sacrifice on write:
 - Logical write = two physical writes
 - Reads may be optimized
- Most expensive solution: 100% capacity overhead
- (RAID 2 not interesting, so skip...involves Hamming codes)



Inspiration for RAID 5

- Use parity for redundancy
 - $D0 \otimes D1 \otimes D2 \otimes D3 = P$
 - If any disk fails, then reconstruct block using parity:
 - e.g., $D0 = D1 \otimes D2 \otimes D3 \otimes P$
- RAID 4: all parity blocks stored on the same disk
 - Small writes are still limited by Parity Disk: Write to D0, D5, both also write to P disk
 - Parity disk becomes bottleneck

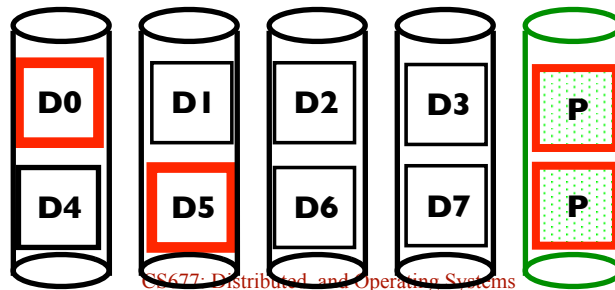

Redundant Arrays of Inexpensive Disks RAID 5: High I/O Rate Interleaved Parity

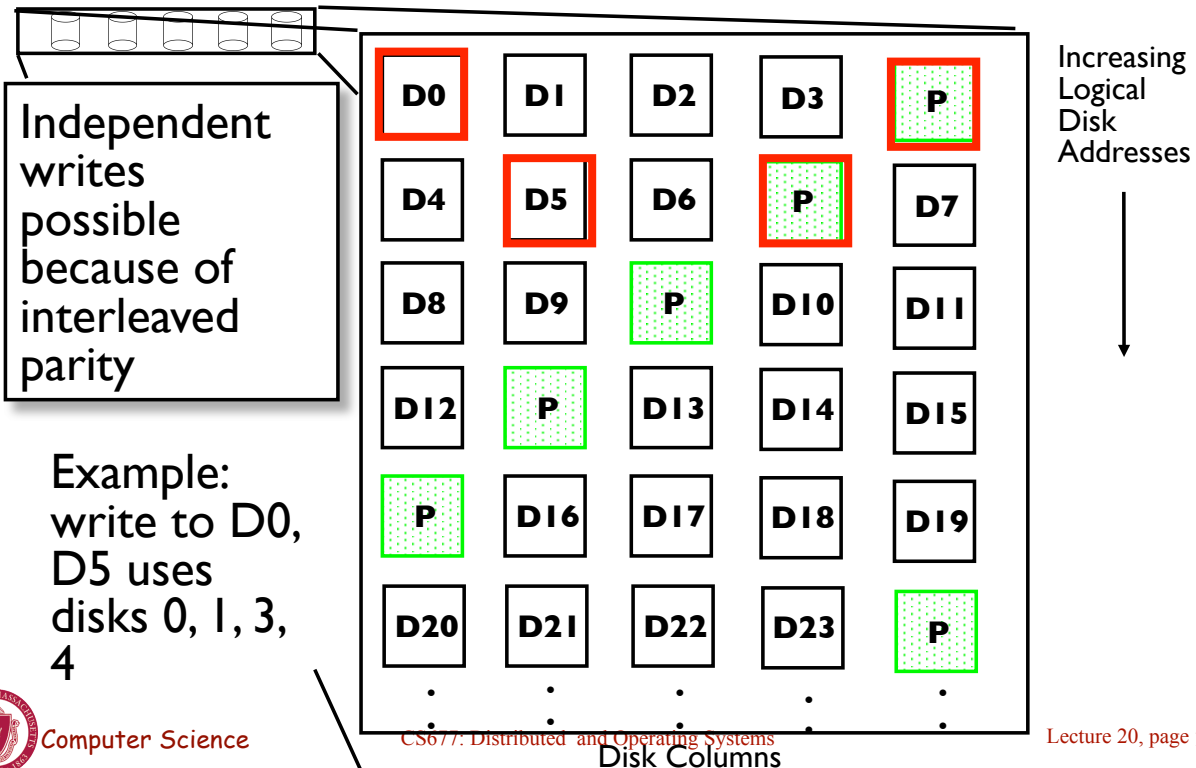

xFS uses software RAID

- Two limitations
 - Overhead of parity management hurts performance for small writes
 - Ok, if overwriting all N-1 data blocks
 - Otherwise, must read old parity+data blocks to calculate new parity
 - Small writes are common in UNIX-like systems
 - Very expensive since hardware RAID add special hardware to compute parity



Log-structured FS

- Provide fast writes, simple recovery, flexible file location method
- Key Idea: **buffer writes in memory and commit to disk in large, contiguous, fixed-size log segments**
 - Complicates reads, since data can be anywhere
 - Use per-file inodes that move to the end of the log to handle reads
 - Uses in-memory imap to track mobile inodes
 - Periodically checkpoints imap to disk
 - Enables “roll forward” failure recovery
- Drawback: must clean “holes” created by new writes



Combine LFS with Software RAID

- The principle of log-based striping in xFS
 - Combines striping and logging

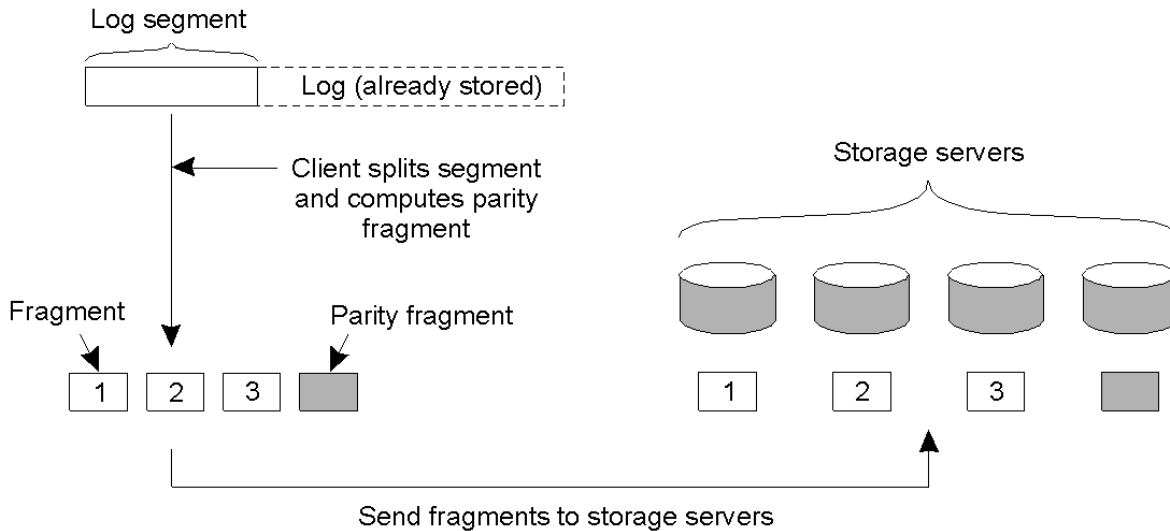

HDFS

- Hadoop Distributed File System
 - High throughput access to application data
 - Optimized for large data sets (accessed by Hadoop)
- Goals
 - Fault-tolerant
 - Streaming data access: batch processing rather than interactive
 - Large data sets: scale to hundreds of nodes
 - Simple coherency model: WORM (files don't change, append)
 - Move computation to the data when possible



HDFS Architecture

- Principle: meta data nodes separate from data nodes
- Data replication: blocks size and replication factor configurable

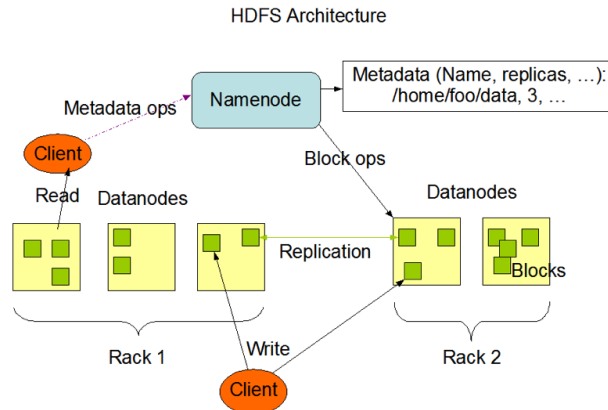

Google File System

- Master-slave; file divided into chunks (replicated thrice)
- Atomic writes

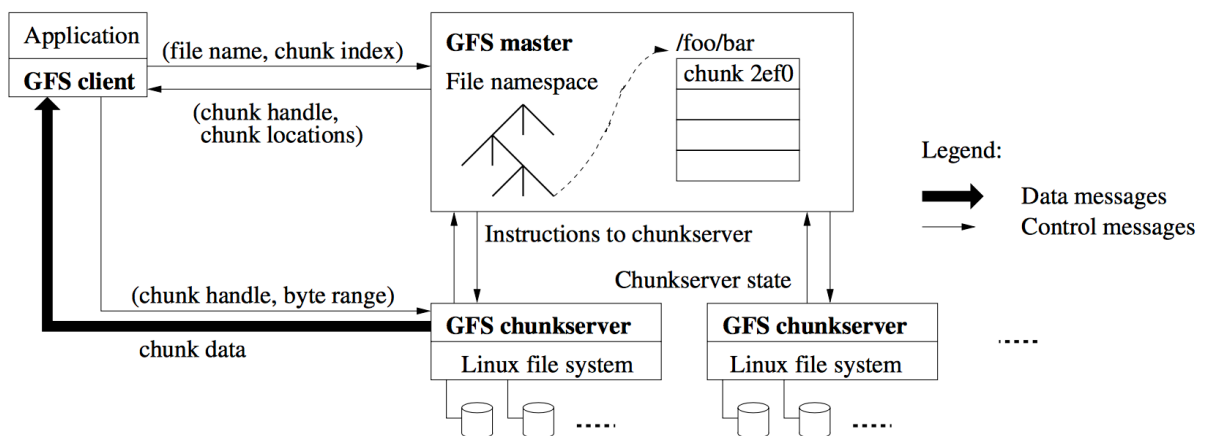

Figure 1: GFS Architecture



Object Storage Systems

- Use handles (e.g., HTTP) rather than files names
 - Location transparent and location independence
 - Separation of data from metadata
- No block storage: objects of varying sizes
- Uses
 - Archival storage
 - can use internal data de-duplication
 - Cloud Storage : Amazon S3 service
 - uses HTTP to put and get objects and delete
 - Bucket: objects belong to bucket/ partitions name space

