

Today: Logical Clocks

- Last class: clock synchronization
- Logical clocks
- Vector clocks
- Global state and distributed snapshots



Logical Clocks

- For many problems, internal consistency of clocks is important
 - Absolute time is less important
 - Use *logical* clocks
- Key idea:
 - Clock synchronization need not be absolute
 - If two machines do not interact, no need to synchronize them
 - More importantly, processes need to agree on the *order* in which events occur rather than the *time* at which they occurred



Event Ordering

- *Problem:* define a total ordering of all events that occur in a system
- Events in a single processor machine are totally ordered
- In a distributed system:
 - No global clock, local clocks may be unsynchronized
 - Can not order events on different machines using local times
- Key idea [Lamport]
 - Processes exchange messages
 - Message must be sent before received
 - Send/receive used to order events (and synchronize clocks)



Happened Before Relation

- If A and B are events in the same process and A executed before B , then $A \rightarrow B$
- If A represents sending of a message and B is the receipt of this message, then $A \rightarrow B$
- Relation is transitive:
 - $A \rightarrow B$ and $B \rightarrow C \Rightarrow A \rightarrow C$
- Relation is undefined across processes that do not exchange messages
 - Partial ordering on events



Event Ordering Using *HB*

- Goal: define the notion of time of an event such that
 - If $A \rightarrow B$ then $C(A) < C(B)$
 - If A and B are concurrent, then $C(A) <, =$ or $> C(B)$
- Solution:
 - Each processor maintains a logical clock LC_i
 - Whenever an event occurs locally at i , $LC_i = LC_i + 1$
 - When i sends message to j , piggyback LC_i
 - When j receives message from i
 - If $LC_j < LC_i$ then $LC_j = LC_i + 1$ else do nothing
 - Claim: this algorithm meets the above goals



Lamport's Logical Clocks

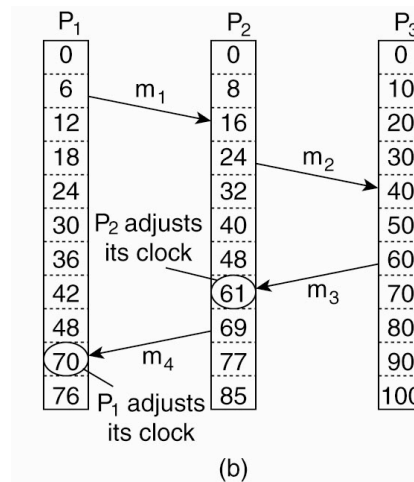
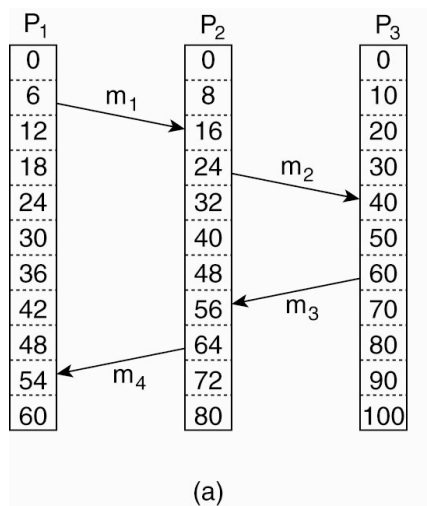

Example: Totally-Ordered

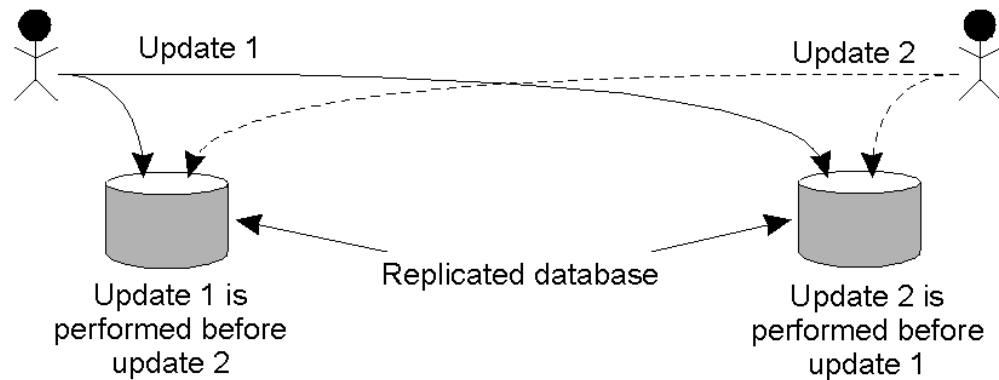

Causality

- Lamport's logical clocks
 - If $A \rightarrow B$ then $C(A) < C(B)$
 - Reverse is not true!!
 - Nothing can be said about events by comparing time-stamps!
 - If $C(A) < C(B)$, then ??
- Need to maintain *causality*
 - If $a \rightarrow b$ then a is causally related to b
 - *Causal delivery*: If $\text{send}(m) \rightarrow \text{send}(n) \Rightarrow \text{deliver}(m) \rightarrow \text{deliver}(n)$
 - Capture causal relationships between groups of processes
 - Need a time-stamping mechanism such that:
 - If $T(A) < T(B)$ then A should have causally preceded B



Vector Clocks

- Each process i maintains a vector V_i
 - $V_i[i]$: number of events that have occurred at i
 - $V_i[j]$: number of events i knows have occurred at process j
- Update vector clocks as follows
 - Local event: increment $V_i[i]$
 - Send a message :piggyback entire vector V
 - Receipt of a message: $V_i[k] = \max(V_j[k], V_i[k])$
 - Receiver is told about how many events the sender knows occurred at another process k
 - Also $V_j[i] = V_j[i] + 1$
- *Exercise:* prove that if $V(A) < V(B)$, then A causally precedes B and the other way around.



Enforcing Causal Communication

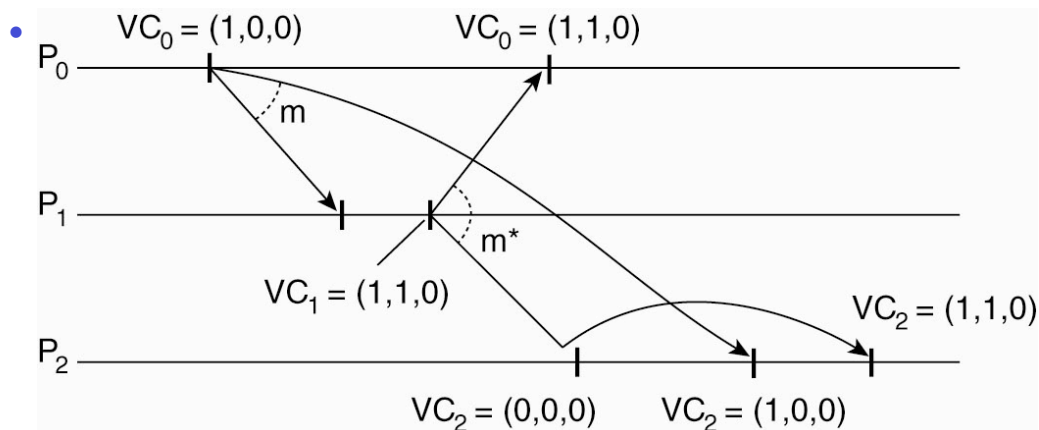

Global State

- Global state of a distributed system
 - Local state of each process
 - Messages sent but not received (state of the queues)
- Many applications need to know the state of the system
 - Failure recovery, distributed deadlock detection
- Problem: how can you figure out the state of a distributed system?
 - Each process is independent
 - No global clock or synchronization
- Distributed snapshot: a consistent global state



Global State (1)

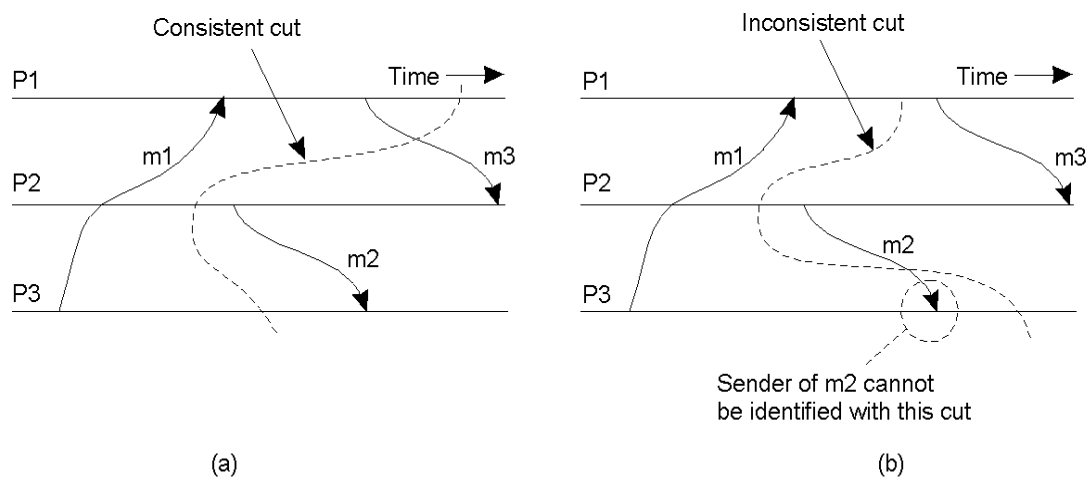

- a) A consistent cut
- b) An inconsistent cut



Distributed Snapshot Algorithm

- Assume each process communicates with another process using unidirectional point-to-point channels (e.g, TCP connections)
- Any process can initiate the algorithm
 - Checkpoint local state
 - Send marker on every outgoing channel
- On receiving a marker
 - Checkpoint state if first marker and send marker on outgoing channels, save messages on all other channels until:
 - Subsequent marker on a channel: stop saving state for that channel



Distributed Snapshot

- A process finishes when
 - It receives a marker on each incoming channel and processes them all
 - State: local state plus state of all channels
 - Send state to initiator
- Any process can initiate snapshot
 - Multiple snapshots may be in progress
 - Each is separate, and each is distinguished by tagging the marker with the initiator ID (and sequence number)

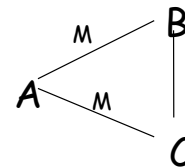

Snapshot Algorithm Example

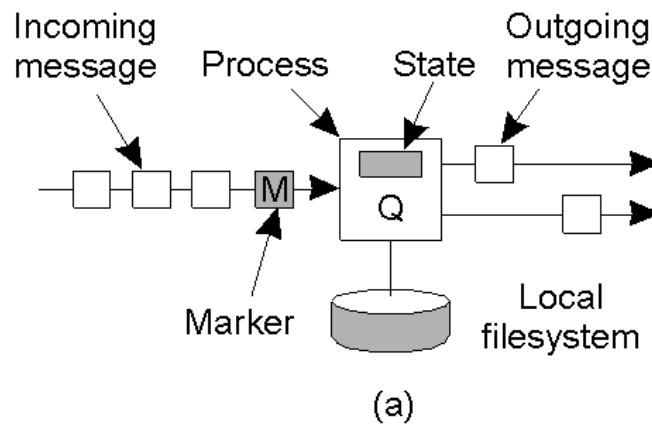

- a) Organization of a process and channels for a distributed snapshot



Snapshot Algorithm Example

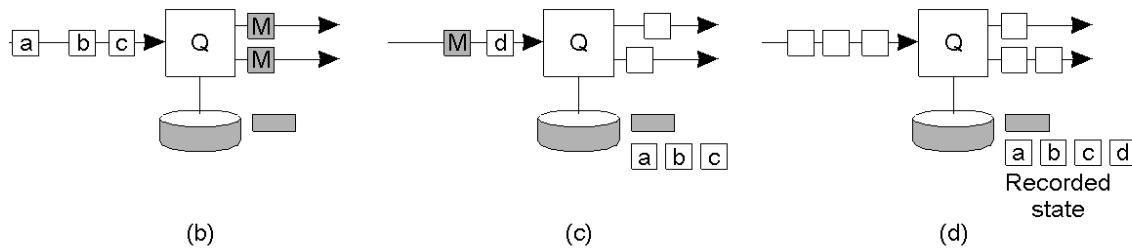

- b) Process Q receives a marker for the first time and records its local state
- c) Q records all incoming message
- d) Q receives a marker for its incoming channel and finishes recording the state of the incoming channel

