

Virtualization

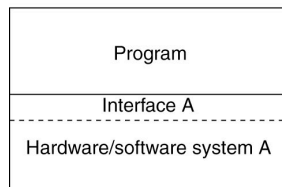

(a)

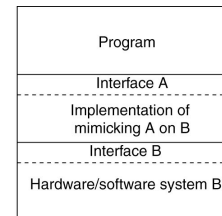

(b)

- Virtualization: extend or replace an existing interface to mimic the behavior of another system.
 - Introduced in 1970s: run legacy software on newer mainframe hardware
- Handle platform diversity by running apps in VMs
 - Portability and flexibility



Types of Interfaces

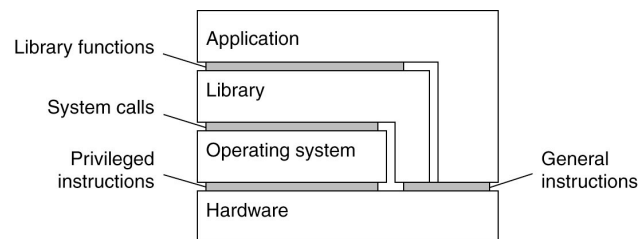

- Different types of interfaces
 - Assembly instructions
 - System calls
 - APIs
- Depending on what is replaced /mimiced, we obtain different forms of virtualization



Types of Virtualization

- Emulation
 - VM emulates/simulates complete hardware
 - Unmodified guest OS for a different PC can be run
 - Bochs, VirtualPC for Mac, QEMU
- Full/native Virtualization
 - VM simulates “enough” hardware to allow an unmodified guest OS to be run in isolation
 - Same hardware CPU
 - IBM VM family, VMWare Workstation, Parallels,...



Types of virtualization

- Para-virtualization
 - VM does not simulate hardware
 - Use special API that a modified guest OS must use
 - Hypercalls trapped by the Hypervisor and serviced
 - Xen, VMWare ESX Server
- OS-level virtualization
 - OS allows multiple secure virtual servers to be run
 - Guest OS is the same as the host OS, but appears isolated
 - apps see an isolated OS
 - Solaris Containers, BSD Jails, Linux Vserver
- Application level virtualization
 - Application is gives its own copy of components that are not shared
 - (E.g., own registry files, global objects) - VE prevents conflicts
 - JVM, Rosetta on Mac (also emulation), WINE



Types of Hypervisors

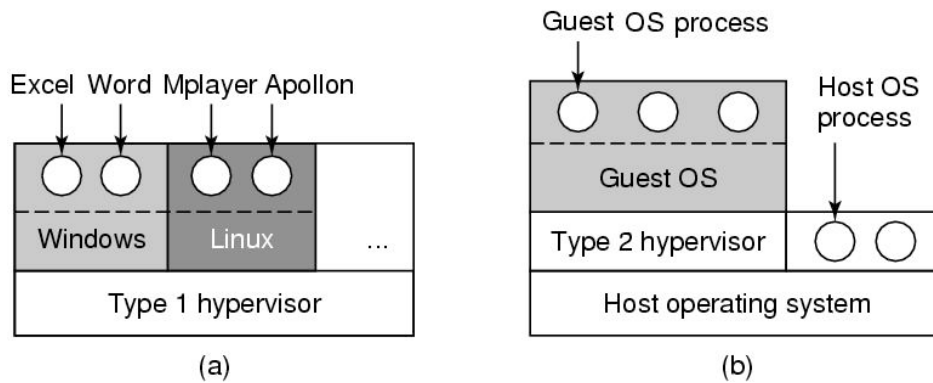

- Type 1: hypervisor runs on “bare metal”
- Type 2: hypervisor runs on a host OS
 - Guest OS runs inside hypervisor
- Both VM types act like real hardware



How Virtualization works?

- CPU supports kernel and user mode (ring0, ring3)
 - Set of instructions that can only be executed in kernel mode
 - I/O, change MMU settings etc -- *sensitive instructions*
 - Privileged instructions: cause a trap when executed in kernel mode
- Result: type 1 virtualization feasible if sensitive instruction subset of privileged instructions
- Intel 386: ignores sensitive instructions in user mode
 - Can not support type 1 virtualization
- Recent Intel/AMD CPUs have hardware support
 - Intel VT, AMD SVM
 - Create containers where a VM and guest can run
 - Hypervisor uses hardware bitmap to specify which inst should trap
 - Sensitive inst in guest traps to hypervisor



Type 1 hypervisor

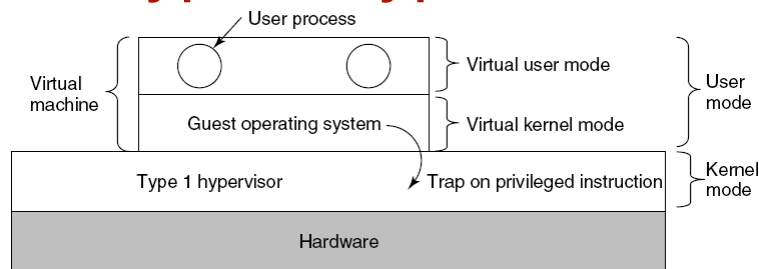

- Unmodified OS is running in user mode (or ring 1)
 - But it thinks it is running in kernel mode (*virtual kernel mode*)
 - privileged instructions trap; sensitive inst-> use VT to trap
 - Hypervisor is the “real kernel”
 - Upon trap, executes privileged operations
 - Or emulates what the hardware would do



Type 2 Hypervisor

- VMWare example
 - Upon loading program: scans code for basic blocks
 - If sensitive instructions, replace by Vmware procedure
 - Binary translation
 - Cache modified basic block in VMWare cache
 - Execute; load next basic block etc.
- Type 2 hypervisors work without VT support
 - Sensitive instructions replaced by procedures that emulate them.



Paravirtualization

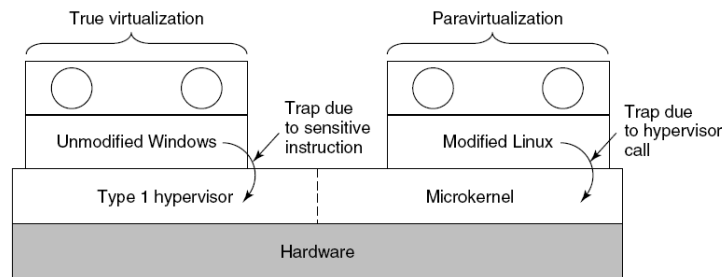

- Both type 1 and 2 hypervisors work on unmodified OS
- Paravirtualization: modify OS kernel to replace all sensitive instructions with hypercalls
 - OS behaves like a user program making system calls
 - Hypervisor executes the privileged operation invoked by hypercall.



Virtual machine Interface

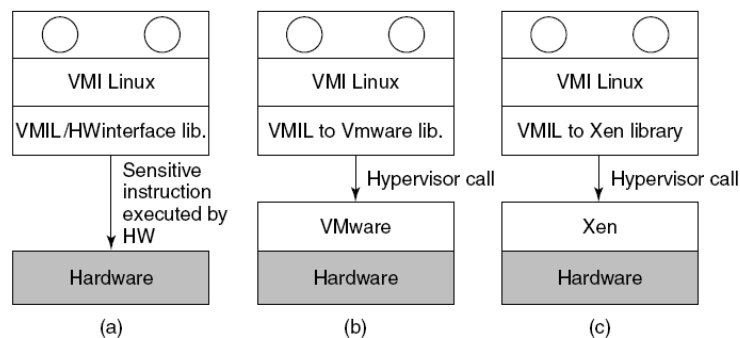

- Standardize the VM interface so kernel can run on bare hardware or any hypervisor



Memory virtualization

- OS manages page tables
 - Create new pagetable is sensitive -> traps to hypervisor
- hypervisor manages multiple OS
 - Need a second shadow page table
 - OS: VM virtual pages to VM's physical pages
 - Hypervisor maps to actual page in shadow page table
 - Two level mapping
 - Need to catch changes to page table (not privileged)
 - Change PT to read-only - page fault
 - Paravirtualized - use hypercalls to inform



I/O Virtualization

- Each guest OS thinks it “owns” the disk
- Hypervisor creates “virtual disks”
 - Large empty files on the physical disk that appear as “disks” to the guest OS
 - Hypervisor converts block # to file offset for I/O
 - DMA need physical addresses
 - Hypervisor needs to translate



Examples

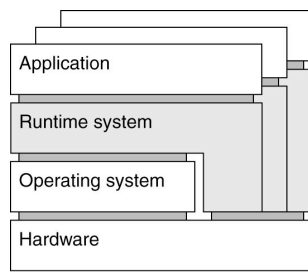

(a)

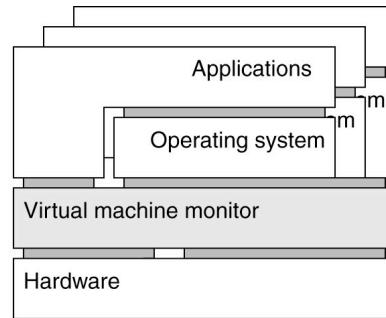

(b)

- Application-level virtualization: “process virtual machine”
- VMM /hypervisor



Virtual Appliances & Multi-Core

- Virtual appliance: pre-configured VM with OS/ apps pre-installed
 - Just download and run (no need to install/comfigure)
 - Software distribution using appliances
- Multi-core CPUs
 - Run multiple VMs on multi-core systems
 - Each VM assigned one or more vCPU
 - Mapping from vCPUs to physical CPUs



Use of Virtualization Today

- Data centers:
 - server consolidation: pack multiple virtual servers onto a smaller number of physical server
 - saves hardware costs, power and cooling costs
- Cloud computing: rent virtual servers
 - cloud provider controls physical machines and mapping of virtual servers to physical hosts
 - User gets root access on virtual server
- Desktop computing:
 - Multi-platform software development
 - Testing machines
 - Run apps from another platform



Case Study: PlanetLab

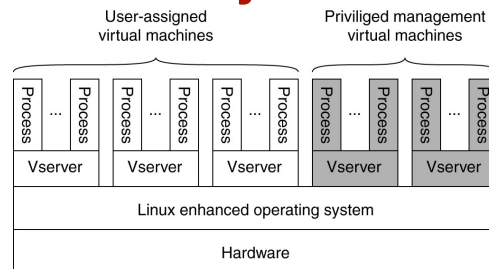

- Distributed cluster across universities
 - Used for experimental research by students and faculty in networking and distributed systems
- Uses a virtualized architecture
 - Linux Vservers
 - Node manager per machine
 - Obtain a “slice” for an experiment: slice creation service

